



User Guide

FXM5

Part Number: 0410-0011-05

Issue Number: 5

Safety Information

Persons supervising and performing the electrical installation or maintenance of a Drive and/or its external Option Unit must be suitably qualified and competent in these duties. They should be given the opportunity to study and if necessary to discuss this User Guide before work is started.

The voltages present in the Drive and external Option Units are capable of inflicting a severe electric shock and may be lethal.

The Stop function of the Drive does not remove dangerous voltages from the terminals of the Drive and external Option Unit. Mains supplies should be removed before any servicing work is performed.

The installation instructions should be adhered to. Any questions or doubt should be referred to the supplier of the equipment. It is the responsibility of the owner or user to ensure that the installation of the Drive and external Option Unit, and the way in which they are operated and maintained complies with the requirements of the Health and Safety at Work Act in the United Kingdom and applicable legislation and regulations and codes of practice in the UK or elsewhere.

The Drive software may incorporate an optional Auto-start facility. In order to prevent the risk of injury to personnel working on or near the motor or its driven equipment and to prevent potential damage to equipment, users and operators, all necessary precautions must be taken if operating the Drive in this mode.

The Stop and Start inputs of the Drive should not be relied upon to ensure safety of personnel. If a safety hazard could exist from unexpected starting of the Drive, an interlock should be installed to prevent the motor being inadvertently started.

General Information

The manufacturer accepts no liability for any consequences resulting from inappropriate, negligent or incorrect installation or adjustment of the optional operating parameters of the equipment or from mismatching the Drive with the motor.

The contents of this User Guide are believed to be correct at the time of printing. In the interests of a commitment to a policy of continuous development and improvement, the manufacturer reserves the right to change the specification of the product or its performance, or the contents of the User Guide, without notice.

All rights reserved. No part of this User Guide may be reproduced or transmitted in any form or by any means, electrical or mechanical including photocopying, recording or by any information storage or retrieval system, without permission in writing from the publisher.

Contents

1	Introduction	1
1.1	Purpose of the FXM5 field-current controller	1
1.2	System control modes	1
1.3	Main features	1
2	Data	3
3	Installation	4
3.1	Hazardous areas	4
3.2	Environment	4
3.3	Mounting instructions	4
3.4	Cables and fuses	5
3.5	Access to the power and signal connectors	6
3.6	Power connections	7
3.7	Armature connections and fuses	8
3.8	EMC recommendations	9
3.9	Signal connections	11
4	Setting Up	15
4.1	Control-system description	15
4.2	Control-circuit description	16
4.3	Setting the thyristor control mode	17
4.4	Setting the value of IFmax	19
4.5	Changing the DCCT primary winding turns	21
4.6	Setting the armature-voltage range	22
4.7	Setting the maximum and minimum field current	22
4.8	Adjusting the armature-voltage threshold	24
5	Fault Finding	25

Declaration of Conformity

Control Techniques, The Gro, Newtown, Powys, UK. SY16 3BE

The AC variable speed drive product FXM5, current range 2A to 20A has been designed and manufactured in accordance with the following European harmonised, national and international standards:

EN60249	Base materials for printed circuits
IEC326-1	Printed boards: general information for the specification writer
IEC326-5	Printed boards: specification for single- and double-sided printed boards with plated-through holes
IEC326-6	Printed boards: specification for multilayer printed boards
IEC664-1	Insulation co-ordination for equipment within low-voltage systems: principles, requirements and tests
EN60529	Degrees of protection provided by enclosures (IP code)
UL94	Flammability rating of plastic materials

This product complies with the Low Voltage Directive 73/23/EEC and the CE Marking Directive 93/68/EEC.

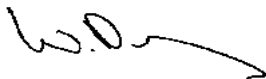

W. Drury
Executive VP Technology
Date: 9 December 1996

This electronic drive product is intended to be used with an appropriate motor, controller, electrical protection components and other equipment to form a complete end product or system. It must only be installed by a professional assembler who is familiar with requirements for safety and electromagnetic compatibility ("EMC"). The assembler is responsible for ensuring that the end product or system complies with all the relevant laws in the country where it is to be used. Refer to the product manual or EMC data sheet for further information on EMC standards complied with by the product, and guidelines for installation.

1 Introduction

1.1 Purpose of the FXM5 field-current controller

The FXM5 field-current controller allows wound-field DC motors to be run at speeds above base-speed. This is achieved by automatically reducing the field current which reduces the magnetic flux. This, in turn, reduces the back-emf in the armature windings. The result is an increase in armature current, and a consequent increase in speed. When a motor is operated under these conditions above base-speed, power output from the motor remains constant since the available torque reduces in inverse proportion to increases in speed.

The motor is normally controlled in a closed-loop system by a variable speed drive (such as a Control Techniques Mentor II Drive).

1.2 System control modes

The FXM5 controller can be used in the following system control modes:

1.2.1 Analog control

The motor speed is controlled by a variable speed drive which varies the armature voltage. The FXM5 controller monitors the armature voltage. When this has reached a preset level (usually the level for base-speed), the controller reduces the field current. This gives automatic field weakening resulting in constant power above base-speed. A suitable speed feedback device must be fitted to the motor shaft and used by the Drive.

1.2.2 Digital control

The motor speed is controlled by a Control Techniques Mentor II Drive which varies the armature voltage, and controls the field current using the FXM5 controller.

Basic PI loop gain adjustments can be made in the Mentor II Drive. Highly precise control of motor speed above base-speed can be obtained.

The FXM5 controller can be controlled by the Mentor II Drive to give automatic field weakening (see *Analog control* above), or to reduce the field current to a preset level when a specified speed has been reached.

A suitable speed feedback device must be fitted to the motor shaft and used by the Drive.

1.2.3 External control of the field current

An external source can be used for either of the following:

- Field weakening by applying a variable field-current reference signal (e.g. from a system controller such as a PLC). A suitable speed feedback device must be fitted to the motor shaft and used by the system controller.
- Fixed level of field current (e.g. using an external preset potentiometer).

1.2.4 Internal control of the field current

The field current is set at a fixed level using a preset potentiometer in the FXM5 controller. The motor can then be run with a reduced field current at fixed or varying speed.

1.3 Main features

1.3.1 AC supply requirements

The FXM5 controller operates on a single-phase AC supply. The AC supply is rectified and controlled by thyristors which can be used to give half-control or full-control as required.

The AC supply to the FXM5 controller must be isolated externally.

1.3.2 Field economy

Control of the field current can be over-ridden to a field-economy level using an external switch. This can be used for the following purposes:

- Over-ride the normal field current when the motor is stationary in order to prevent over-heating of the motor
- By keeping the motor warm, prevent atmospheric condensation in the motor when it is not in use

1.3.3 Mounting arrangement

The FXM5 controller is contained in a module which must be mounted on a vertical surface. Heat generated in the thyristors is dissipated to the air by a finned heatsink. Ingress protection conforms to IP10.

1.3.4 Controls and indicators

Recessed preset potentiometers and LED indicators on the front panel of the module are used for setting up and monitoring the FXM5 controller.

1.3.5 Protection

Change-over relay contacts are operated when the field current reduces to the minimum field current set by the user. The relay contacts can be used to disconnect the motor to prevent run-away in the event of loss of field current.

2 Data



The voltages present in the FXM5 controller are capable of inflicting a severe electric shock and may be lethal. The Stop function of the Drive does not remove dangerous voltages from the FXM5 controller or the driven machine. AC supplies to the FXM5 controller must be disconnected at least 5 minutes before any cover is removed or servicing work is performed.

Electrical	
Permissible AC supply voltage for the controller power supply	220 ~ 254V \pm 10% 380 ~ 440V \pm 10%
AC supply frequency	48Hz ~ 62Hz
Permissible AC supply voltage for the thyristor bridge	0 ~ 480V \pm 10%
Number of AC supply phases	1 (or across 2 phases)
Range of control of the field-winding voltage (depending on AC supply voltage)	0V ~ 430V
Field current	20A maximum
Armature voltage	220V ~ 600VDC
Field failure relay contact ratings	250V, 3.5A DC maximum 1000VA, 200W maximum
Environmental	
Ingress protection	IP10 in accordance with IEC539
Operating temperature range	0°C ~ +50°C (32°F ~ 122°F)
Storage temperature range	-40°C ~ +70°C (-40°F ~ 128°F)
Humidity	85% maximum, non-condensing
Derating for altitude	Maximum altitude without derating is 1000m (3200ft). De-rate maximum field current by 1% for each additional 100m (320ft), up to a maximum of 4000m
Heat dissipation	75W maximum
Electromagnetic compatibility (EMC) emissions	When all the following conditions are met, the installation can meet the requirements for conducted emissions of EN50081-2: The specified RFI filter (or ferrite absorber ring and capacitor network) is used The recommendations for the wiring arrangements are as follows
RFI filter	Steatite P2E/025/M7/-
Physical	
Overall dimensions (when installed)	Width: 250mm (9.843in) Height: 187mm (7.362in) Depth: 112mm (4.409in)
Weight	2.5 kg (6 lb)

3 Installation



The equipment enclosure is rated at IP10 in accordance with IEC539. It is designed for installation within a protective enclosure which prevents unauthorised access except for trained service personnel, and prevents contamination with conductive dust and condensation.



The voltages present in the FXM5 controller are capable of inflicting a severe electric shock and may be lethal. The Stop function of the Drive does not remove dangerous voltages from the FXM5 controller or the driven machine. AC supplies to the FXM5 controller must be disconnected using an approved isolation device before any cover is removed or service work is performed.



Electric shock risk

If the FXM5 controller has been energized, the supply must be isolated for at least five minutes. This allows the internal capacitors to discharge fully before work may continue.



Ground connections

The ground connections should be inspected and tested at appropriate and regular intervals.

3.1 Hazardous areas

Approval and certification for hazardous areas should be obtained for the complete installation of the motor, Drive and FXM5 controller.

3.2 Environment

In accordance with the IP10 rating of the FXM5, the FXM5 must be located in an environment that is free from dust, corrosive vapors, gases and all liquids, including condensation of atmospheric moisture (i.e. pollution degree 2 as required by UL840 and IEC664-1).

If condensation is likely to occur when the FXM5 is not in use, install an anti-condensation heater. This heater must be switched off when the FXM5 is in use; automatic switching is recommended.

Install the FXM5 vertically for best flow of cooling air. When the FXM5 is installed in an enclosure, install the FXM5 as low as possible (without contravening EMC requirements).

Observe the requirements for ambient temperature if the FXM5 is to be mounted directly above any heat generating equipment (such as a Drive).

3.3 Mounting instructions

Refer to *section 3.8 EMC recommendations* on page 9. Install the FXM5 controller on a vertical surface (enclosure back-plate) with the heatsink fins vertical. Use the fixing holes in the mounting brackets.

Allow at least 100mm (3.937in) clearance above and below the FXM5 controller to allow free air-flow through the heatsink. Allow at least 3mm (0.118in) clearance each side of the FXM5 controller.

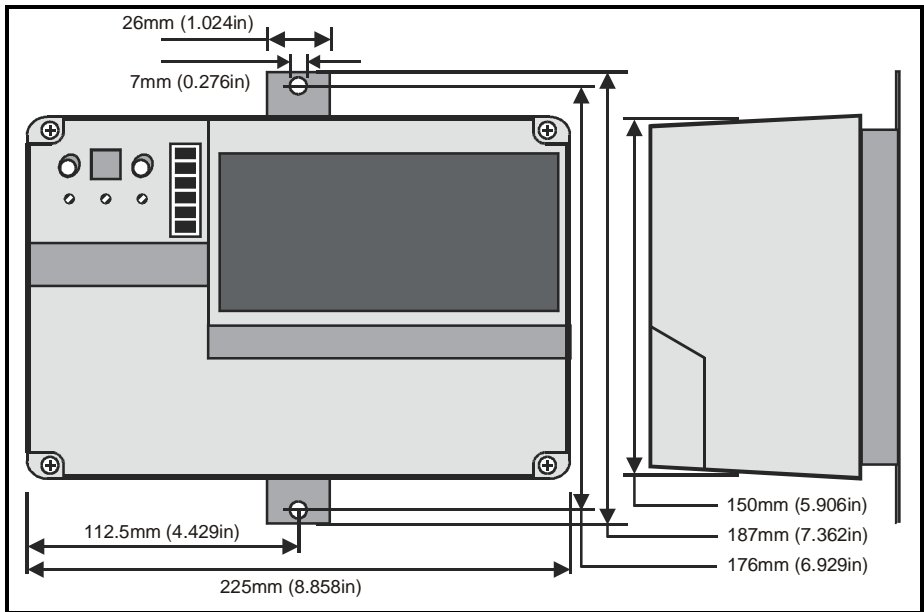

Figure 3-1 Mounting details

3.4 Cables and fuses



The AC supply inputs in the FXM5 controller are fitted with fuses for protection against overload and short circuits in the FXM5 controller and field-winding of the motor. These fuses will not protect the supply cables to the FXM5 controller. The table shows recommended cable sizes and fuse ratings for a number of current levels. Failure to observe this recommendation will cause a risk of fire.



Wiring must be in accordance with local regulations and codes of practice. The table shows typical cable sizes for power input and output wiring. In the event of a conflict, local regulations prevail.

For the following power connections...

- AC supply to the isolator and fuses
- Isolator and fuses to the Drive
- Drive to the motor
- External braking resistor to the Drive (when required)

...use the following:

- 3-core and 4-core pvc-insulated cable with copper conductors having a temperature rating not less than 60/75°C and laid in accordance with defined conditions. Refer to EMC recommendations later in this chapter for shielding requirements.
- The wiring must conform to local regulations and codes of practice. Refer to the following table for the size of the AC supply and field-winding cables. In the event of conflicting data, local regulations prevail.

Cable size		Maximum current and fuse rating
mm ²	AWG	A
1.0	18	2
1.5	16	5
2.5	14	10
4.0	10	20
4.0	10	20

Fuses fitted to the FXM5 controller printed-circuit board are as follows:

Fuse	Rating	Type	Protects...	CT Part number
FS1 FS2	500mA	30mm	Control-circuits power supply	3537-3251
FS3 FS4	20A	HRC	Thyristor bridge and field weakening	3537-3252

3.5 Access to the power and signal connectors

Remove the four corner screws and the front cover. The connectors are mounted on the printed-circuit board which is now exposed.

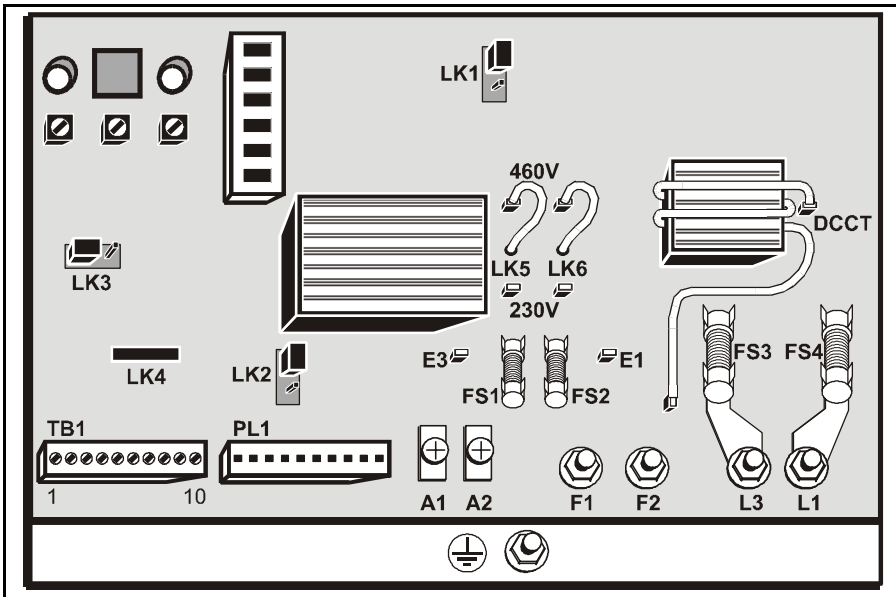

Figure 3-2 Locations of the ground, power and signal connectors, fuses and jumpers

3.6 Power connections

Terminal	Function	Notes
A1 A2	Armature-voltage input	A1 - Positive A2 - Negative (With forward rotation)
F1 F2	Field-winding output	F1 - Positive F2 - Negative
L1 L3	AC supply	See <i>AC supply connections</i>
E1 E3	Alternative AC supply	See <i>AC supply connections</i>

3.6.1 AC supply connections

Using an alternative AC supply

The AC supply applied to terminals L1 and L3 supplies the following:

- **Field winding of the motor (through the thyristor bridge)**
- **Power supply for the control-circuits**

The AC supply voltage must be in the range specified in *Data* on page 3 for the control-circuits power supply. If the voltage is less than 220V \pm 10%, the control-circuits power supply must be supplied by an alternative AC supply having an acceptable voltage. Use the following procedure:

1. Remove fuses FS1 and FS2 from the printed-circuit board in order to ensure isolation between the alternative AC supply and the field-winding AC supply.
2. Connect the alternative AC supply to terminals E1 and E3. Ensure that the alternative supply is connected so that the voltage applied to E1 is in phase with the voltage applied to L1.
3. Ensure that both connections of the alternative supply are protected with 500mA fuses.

NOTE

If the voltage rating of the field is much lower than the supply voltage it is advisable to use a transformer to reduce the supply voltage. This maximises the resolution of the controller and prevents the possibility of excessive voltage being applied to the field winding.

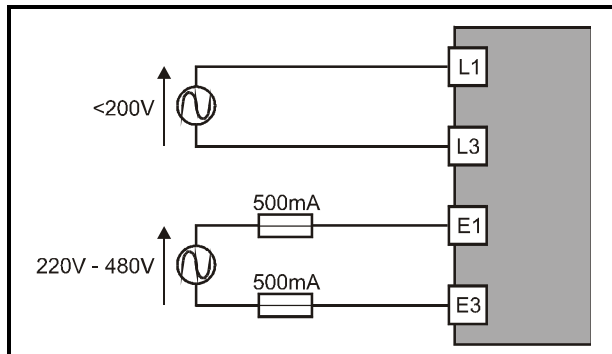

Figure 3-3 Connecting an alternative AC supply in phase with the field-winding supply

Using a Mentor II Drive

When using the FXM5 controller with a Mentor II Drive, ensure that terminals L1 and L3 of the controller are connected to the same phases as L1 and L3 in the Drive.

3.6.2 AC supply voltage

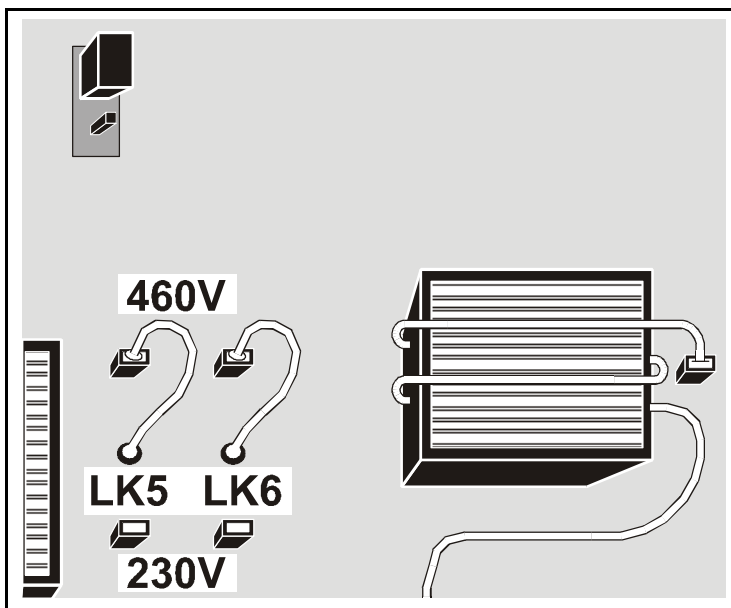

Figure 3-4 Locations of jumpers LK5 and LK6

Set jumpers LK5 and LK6 for the AC supply voltage. (This may be the voltage applied to terminals L1 and L3, or E1 and E3 (see *Using an alternative AC supply* on page 7). Both jumpers must be set for the same voltage.

3.7 Armature connections and fuses

Connections

Make armature connections to terminals A1 and A2 as follows:

System control mode	Connect...
Analog control	Yes
Digital control	No
External control of field current	No
Internal control of field current	No

Fuses

Protect each armature connection with a 2ADC fuse.

3.8 EMC recommendations

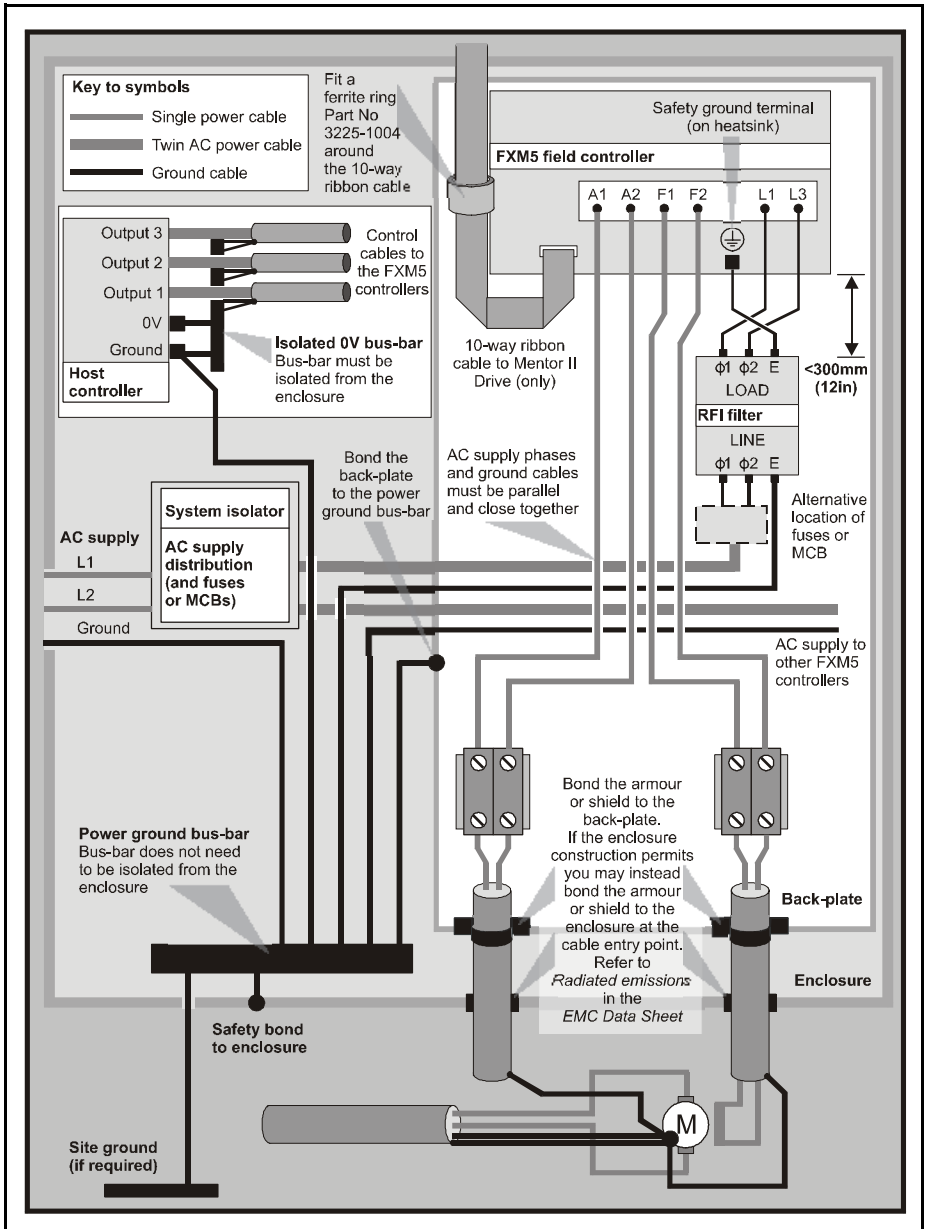

Figure 3-5 EMC wiring recommendations

To minimize radio-frequency emissions, it is necessary to install the FXM5 in a steel enclosure and pay attention to the arrangement of the wiring inside the enclosure. Any number of FXM5 controllers may be installed in an enclosure.

Figure 3-5 shows an example of wiring arrangements for minimum radio-frequency emissions. The actual arrangement used will have to be adapted to individual requirements.

The following conditions must be met:

- The environment is acceptable (see section 3.2 *Environment* on page 4)
- The maximum permissible ambient temperature is not exceeded
- The EMC requirements are met
- The electrical installation meets safety requirements

3.8.1 Motor cable

In order to meet the EMC emissions requirements, it is preferable that one of the following conditions applies for the motor cable:

- If the cable is to be entirely enclosed in grounded metal ducting, the cable does not need to be shielded or armoured.
- If the FXM5 is to be mounted in a machine that has a grounded metal case, and the motor cable is to be contained inside the case, the cable does not need to be shielded or armoured.
- If the cable is to be exposed, it should be armoured or shielded. Alternatively, unshielded cable could be used if an RFI filter is included in the output circuit of the FXM5.
- If the length of the motor cable does not exceed 50 metres, very little radiation should be produced. In this case, unshielded cable may be used on condition that the EMC emissions requirements of the installation are considered.

3.8.2 RFI filter

An RFI filter type **P2E/025/M7/-** must be connected as shown in the AC supply circuit to the FXM5. Mount the RFI filter beneath the FXM5 with a clearance of 300mm (12in).

Use the same type of filter if an RFI filter is to be included in the output circuit of the FXM5.



The filter must be used in conjunction with a suitable RFI filter for the armature supply. The filter input must obtain its supply from the input of the armature filter and line chokes, otherwise it may be over-heated and possibly damaged by the armature voltage notching.

3.8.3 Ground connections

The ground stud on the heatsink of the FXM5 must be connected to the power ground bus-bar. This bus-bar must be connected to the enclosure ground by a safety ground connection. It is essential that these connections are permanently installed, and cannot be inadvertently disconnected.

The size of external grounding terminals should be appropriate to the size of the grounding cables.

Ground loop impedance must conform to the requirements of local industrial safety regulations.

Do not connect the signal 0V common connections to ground at the FXM5. Connect them to ground at the isolated 0V bus-bar.

3.9 Signal connections

3.9.1 Analog control

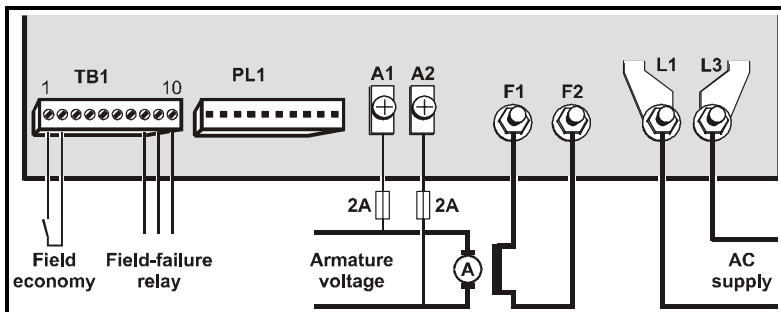

Figure 3-6 Power and signal connections for analog control

Make signal connections to terminal block TB1, as follows:

TB1	Function	
1	Field economy contact	Connect to terminal 2 for normal operation Disconnect for field economy
2	0V common	
3	Field-current amplifier input	Do not connect
4	-15V, 10mA max. output	Use to supply external devices
5	+15V, 10mA max. output	Use to supply external devices
6	Field-current output signal	0 to 10V represents 0 to I _F max.
7	Armature-voltage output signal	0 to ±10V represents 0 to ±600V armature voltage
8	Field-current failure relay	Common contact
9		Contact closed when field current is normal
10		Contact open when field current is normal

3.9.2 Digital control

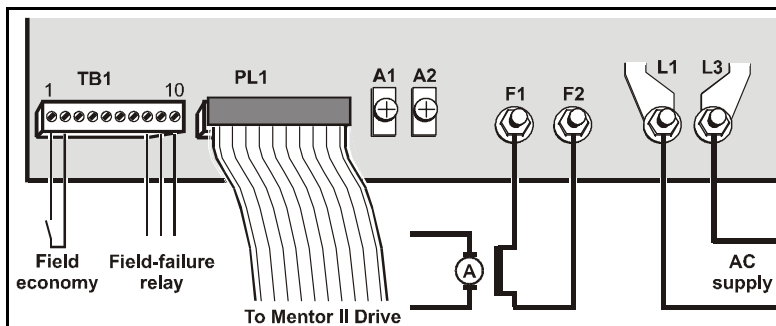

Figure 3-7 Power and signal connections for digital control

Digital control can be obtained only by connecting a Control Techniques Mentor II Drive to PL1 of the FXM5 controller using the 10-way ribbon cable supplied with the controller. When the cable is connected, the FXM5 control circuits are automatically disconnected from the thyristor bridge driver N5; The Mentor II Drive then controls the bridge driver directly.

Use Menu-6 parameters in the Mentor II Drive to set up and control the FXM5 controller. Remove the following jumpers from the power boards of the Mentor II Drive:

Model	Jumper
M25 to M210	LK1 and LK2
M350 to M1850	LK1

3.9.3 Connections to the Mentor Drive

Model	Mentor Power Board	Connector Designation
M25-M75	MDA75	PL6
M25R-M75R	MDA75R	PL6
M105-M210	MDA210	PL6
M105R-M210R	MDA210R	PL6
M350-M1850	MDA6	PL16
M350R-M1850R	MDA6	PL16

3.9.4 External control of the field current (variable or fixed levels)

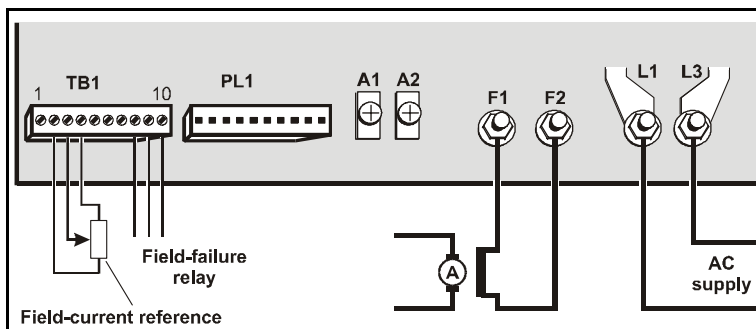

Figure 3-8 Power and signal connections for external control of the field current

Make signal connections to terminal block TB1, as follows:

TB1	Function	
1	Field economy contact	Not used
2	0V common	
3	Field-current amplifier input	Apply an external field-current reference signal (0 to -10V) Remove jumper LK4
4	-15V, 10mA max. output	Use to supply external devices (e.g. external field-current reference potentiometer)
5	+15V, 10mA max. output	Use to supply external devices
6	Field-current output signal	0-10V represents 0 to I_F max
7	Armature-voltage output signal	Not used
8		Common contact
9	Field-current failure relay	Contact closed when field current is normal
10		Contact open when field current is normal



The field current must not be allowed to become zero while the motor is running.

Cut the wire jumper LK4 since stages N1, N2 and N3 are not used and must not affect the system (see section 4.2 *Control-circuit description* on page 16).

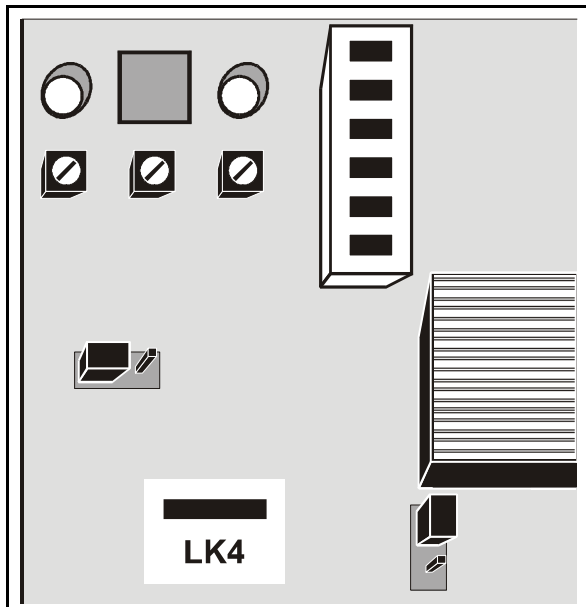

Figure 3-9 Location of wire jumper LK4

3.9.5 Internal control of the field current (fixed level)

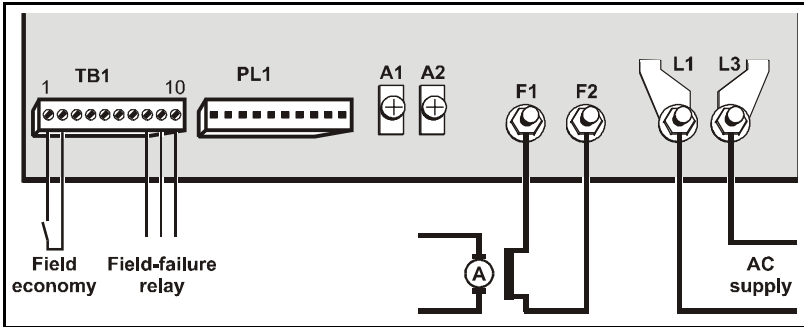

Figure 3-10 Power and signal connections for internal control of the field current

Make signal connections to terminal block TB1, as follows:

TB1	Function	
1	Field economy contact	Connect to terminal 2 for normal operation. Open circuit for field economy.
2	0V common	
3	Field-current amplifier input	Do not connect
4	-15V, 10mA max. output	Use to supply external devices
5	+15V, 10mA max. output	Use to supply external devices
6	Field-current output signal	0-10V represents 0 to I_F max
7	Armature-voltage output signal	Not used
8	Field-current failure relay	Common contact
9		Contact closed when field current is normal
10		Contact open when field current is normal

3.9.6 Field economy

When the FXM5 controller is in normal use, connect TB1 terminal 1 to terminal 2. This can be achieved using external contacts. When field economy is required, the contacts should be opened. The field current is reduced to the minimum value set using RV2.

When the FXM5 is being controlled from the Mentor using Menu 6 the field current can be reduced by controlling parameter **6.14**. The field can be automatically reduced if the armature is disabled. This function is controlled by parameter **6.12**, **6.15**.

4 Setting Up

4.1 Control-system description

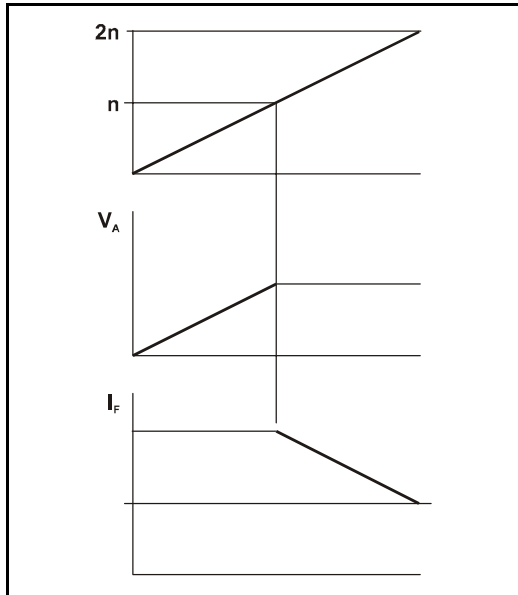

Figure 4-1 Control of armature voltage and field current with varying motor speed

Refer to Figure 4-1. The FXM5 controller maintains the field current I_F at a fixed value until base speed n is reached (detected by the armature voltage V_A reaching a maximum value). Attempts by the Drive to increase the speed by further increasing the armature voltage causes the controller to reduce the field current. Because the Drive, FXM5 controller and motor operate in a closed loop, the armature voltage remains constant when the speed is varied above base-speed, but the field current is reduced in inverse proportion to increases in speed. For example, to allow the motor speed to reach double the base-speed, the field current must be halved.

4.2 Control-circuit description

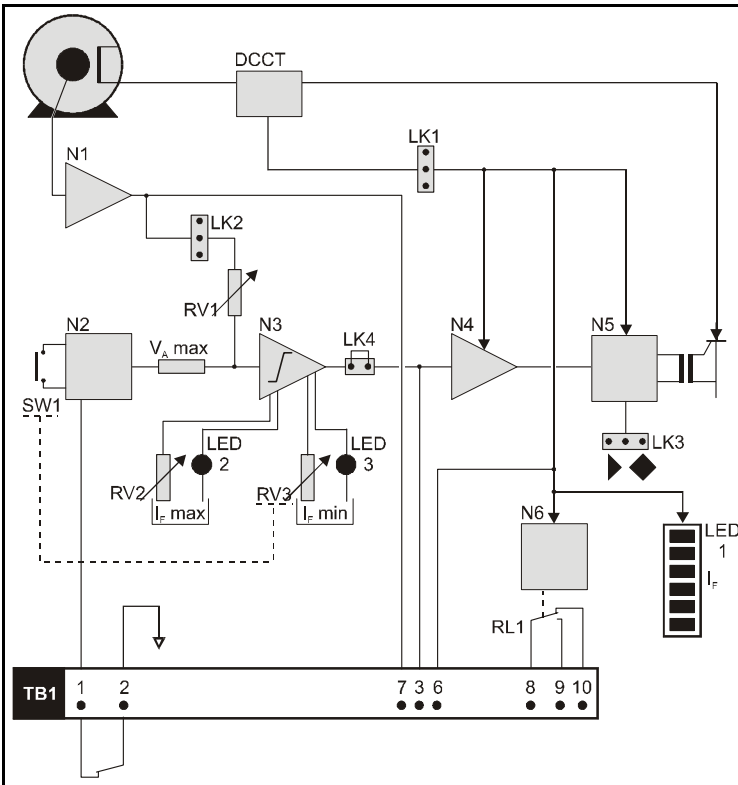

Figure 4-2 Main elements of the control circuit

Refer to Figure 4-2. The control circuit comprises four main elements, as follows:

- Armature-voltage monitor (N1, N2)
- Field-current limiter (N3)
- Field-current amplifier (N4)
- Thyristor-bridge driver (N5)

The elements that are used depend on the *system control mode* that is in operation.

4.2.1 Main elements

The armature-voltage is applied to amplifier N1. The output is compared with a voltage reference N2. Preset potentiometer RV1 (**MAX ARM V**) and jumper LK2 are used to adjust the threshold level. When a Mentor II Drive is used parameter **6.07** sets the threshold. When the threshold level is not reached, the resulting signal causes the field-current limiter (N4) and thyristor-bridge driver (N5) to apply full voltage to the field winding of the motor. When the threshold is reached, the field-current limiter (N4) and thyristor-bridge driver (N5) cause the field-winding voltage to be reduced.

A direct-current current-transducer (DCCT) in the field-winding circuit monitors the field current. The output of the DCCT is applied to a negative feedback loop so that, by varying the field-winding voltage, the FXM5 controller is in control of the field current. The setting of jumper LK1 and the number of primary-winding turns through the DCCT define the absolute maximum current ($I_F \text{max}$) that can be produced by the controller

(see section 4.5 *Changing the DCCT primary winding turns* on page 21). This value should be set at the nearest value above the required maximum field current.

Preset potentiometer RV2 (**SET MAX FIELD**) is used to set the required maximum field current as a proportion of $I_f\text{max}$. This current level occurs when the armature voltage is below the preset threshold. LED2 indicates when the field current is at the maximum level set using RV2. When a Mentor II Drive is used, the required maximum current can be set using parameter **6.08**.

Preset potentiometer RV3 (**SET MIN FIELD**) and switch SW1 are used to adjust the minimum level of field current as a proportion of the current set using RV2. When SW1 is pressed, the LED bar indicator indicates proportion of the maximum current set using RV2. The minimum level should be set for maximum required motor speed. When a Mentor II Drive is used, the required minimum current can be set using parameter **6.10**.

LED3 indicates when the field current is at or below the minimum level set using RV3.

The field-current feedback signal is monitored by an LED bar indicator, (LED1) and N6. The LED bar indicates proportion of absolute maximum current ($I_f\text{max}$) in steps of 0.1 (10%).

When the FXM5 controller is operating normally, field-failure relay RL1 is energized by N6. When the field current is detected by N6 to be below the setting of RV2 (or the minimum current set by a Mentor II Drive), the relay is de-energized. The contacts can be used to break the AC supply to the armature.

4.3 Setting the thyristor control mode

All system control modes

4.3.1 Description

The thyristors are arranged as a full-wave bridge rectifier. The thyristors can be controlled so that the bridge gives half-control or full-control. In both cases, full-wave rectification is obtained. The results are as follows:

Half-control

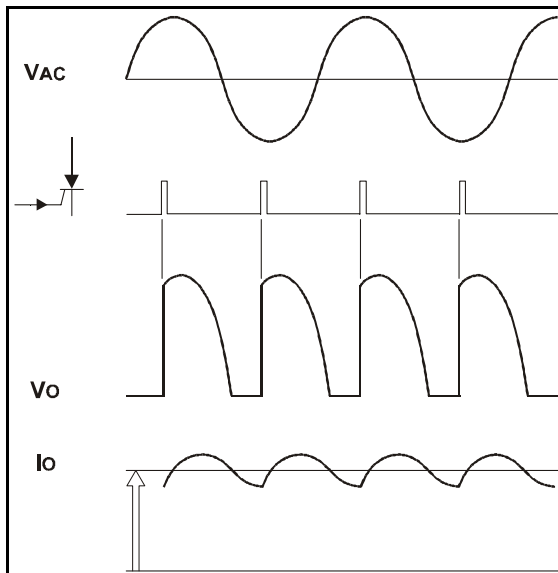

Figure 4-3 Waveforms resulting from half-control

Full-control

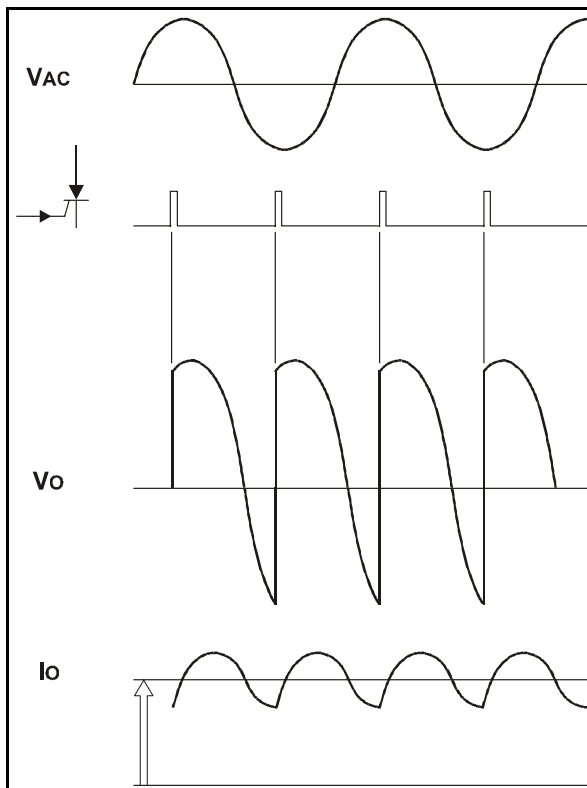

Figure 4-4 Waveforms resulting from full-control

4.3.2 Recommendations

Half-control

Normally use half-control, since this generally produces a lower amplitude of current ripple. This results in lower torque ripple in the motor.

Full-control

Full control causes the thyristor bridge to force the field current more rapidly towards zero at each half cycle. This increases the amplitude of the ripple current, but gives faster control of the field-current level. Use full-control under the following conditions:

- When very rapid field-weakening is required
- Motors that have an unusually long electrical time-constant ($\frac{L}{R}$)

4.3.3 Procedure

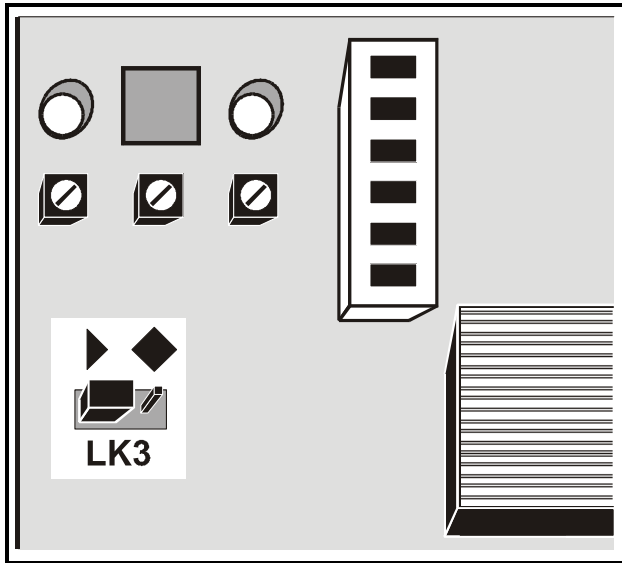



Figure 4-5 Location of jumper LK3

Set the required thyristor control mode using jumper LK3.

Key to symbols	
	Half-control position
	Full-control position

4.4 Setting the value of $I_f\text{max}$

All system control modes

4.4.1 Description

The maximum field current ($I_f\text{max}$) that can be delivered by the FXM5 controller depends on the following:

- Number of primary-winding turns through the DCCT
- Setting of jumper LK1

Refer to the following table.

Maximum field current	Number of primary turns	LK1 setting		Setting of parameter 6.11
		15/Np	20/Np	
1	10	✓		1
2	10		✓	2
3	5	✓		3
4	5		✓	4
5	4		✓	5
6	3		✓	6
7	2		✓	7
8	2		✓	8
9	2		✓	9
10	2		✓	10
11	1	✓		11
12	1	✓		12
13	1	✓		13
14	1	✓		14
15	1	✓		15
16	1		✓	16
17	1		✓	17
18	1		✓	18
19	1		✓	19
20	1		✓	20

The maximum field current is derived as follows:

$$I_{Fmax} = \frac{20}{N_p} \text{ or } \frac{15}{N_p}$$

When the FXM5 controller is used with a Mentor II Drive, parameter **6.11** must be set at the value stated in the table.

The FXM5 controller is supplied having two turns through the DCCT. (The number of turns is defined by the number of times the wire passes *through* the hole in the DCCT).

4.4.2 Procedure

Set the value of **I_{Fmax}** at the nearest value above the maximum required field current. At a later stage, you can set the maximum field current at the required value using the **SET MAX FIELD** potentiometer or parameter **6.08**.

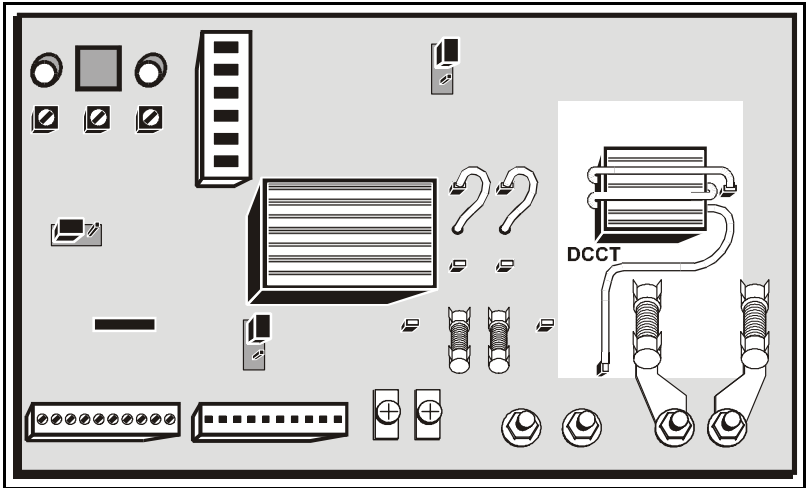

Figure 4-6 Location of the DCCT and wire loop

4.5 Changing the DCCT primary winding turns

Use the following procedure to change the number of turns:

1. Disconnect the loop of wire from the spade connectors on the printed-circuit board and remove the wire from the DCCT.
2. Use insulated wire of sufficient length for the required number of turns and ensure the wire is of the correct size for the maximum field current. (Refer to *Cables and fuses* on page 5)
3. Loop the wire through the DCCT in the same direction as the original wire.
4. Fit a 6.25mm (0.276in) spade receptacle to each end of the wire.
5. Connect the wire to the spade connectors on the board.
6. Set jumper LK1 at the setting given in the table.

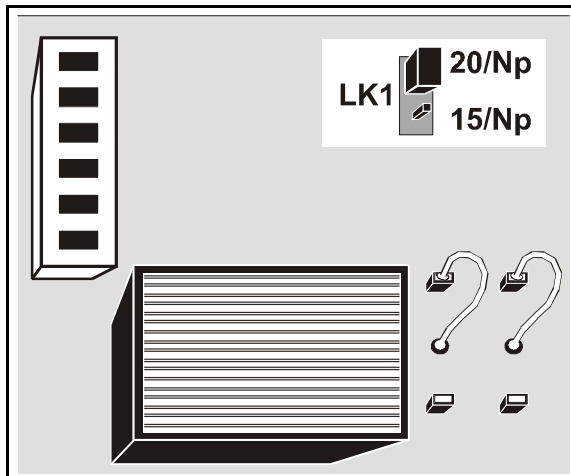

Figure 4-7 Location of jumper LK1

4.6 Setting the armature-voltage range

Analog control mode

Digital control mode

4.6.1 Procedure

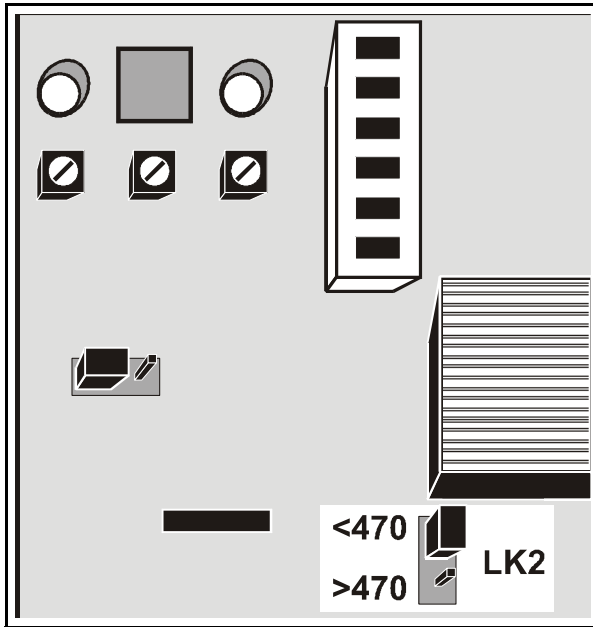

Figure 4-8 Location of jumper LK2

Set jumper LK2 as follows:

Maximum armature voltage	Setting
0 ~ ±470V	<470
>±470V	>470

4.7 Setting the maximum and minimum field current

Analog control mode

External control of the field-current

Internal control of the field-current



During the following procedures, you will be required to apply AC power to the FXM5 controller and the motor. Before applying AC power, ensure the following:

- The controller is correctly connected
- The controller cover is securely fitted

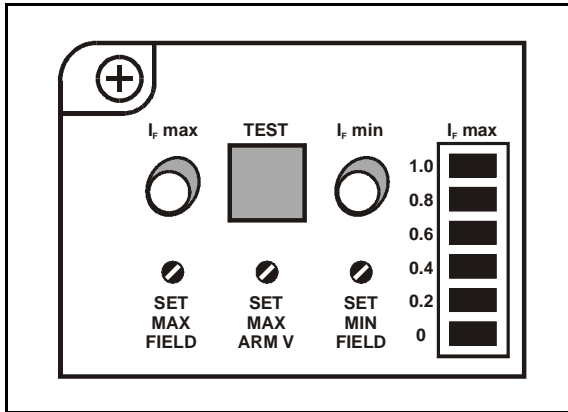

Figure 4-9 Locations of the controls and indicators on the front panel

4.7.1 Maximum current

Apply AC power to the FXM5 controller. Do not start the motor running.

Monitor the LED bar indicator and adjust the **SET MAX FIELD** potentiometer to set the current at the required proportion of I_{Fmax} . Check that the I_{Fmax} LED is lit.

Note that the LED bar indicator relates to the absolute maximum current that can be produced by the controller as determined by the setting of jumper LK1 and the number of primary-winding turns in the DCCT. The absolute maximum current is defined as I_{Fmax} . The title I_{Fmax} on the LED above the **SET MAX FIELD** potentiometer relates to the maximum required current set using the potentiometer, not the absolute maximum current of the FXM5 controller.

4.7.2 Minimum current

1. Press the **TEST** switch continuously. The LED bar indicator now shows the proportion of current set using the **SET MAX FIELD** potentiometer.
2. Monitor the LED bar indicator and adjust the **SET MIN FIELD** potentiometer to set the current at the required proportion of the maximum level. Check that the I_{Fmin} LED is lit.

The value of minimum field current that can be set is between 0.1 and 0.9 of the maximum. The minimum current should be set to either of the following:

- To just below the field current required for the maximum speed (e.g. for double the base-speed, set the **SET MIN FIELD** potentiometer for just below half the current set using the **SET MAX FIELD** potentiometer. The field-failure relay will be de-energized when the field current reduces to the level set using the **SET MIN FIELD** potentiometer.
 - To define a level for the field-failure relay to be de-energized, independently of the minimum required field current.
3. Release the **TEST** switch.
 4. Remove AC power from the FXM5 controller and from the field winding of the motor.

4.7.3 Fixed field current

Use the procedure given above to set the maximum field current. Set the minimum field current at a level for the field-failure relay to be de-energized.

Set the **MAX ARM V** potentiometer at the fully clockwise position.

4.8 Adjusting the armature-voltage threshold

Analog control mode



During the following procedure, you will be required to apply AC power to the FXM5 controller and to run the motor. Before applying AC power, ensure the following:

- The controller is correctly connected**
- The controller cover is securely fitted**
- The motor can be run safely**

Use the following procedure to adjust the FXM5 controller to begin field-weakening at the required armature voltage:

1. Set the **SET MAX ARM V** potentiometer at the fully clockwise position.
2. Apply AC power to the Drive and FXM5 controller.
3. Set the Drive to run the motor at base-speed, (or at the required speed if field-weakening is to start at a lower speed).
4. Slowly turn **SET MAX ARM V** potentiometer anti-clockwise until the highest illuminated segment of the LED bar indicator becomes extinguished.
5. Stop the motor and remove AC power from the system.

5 Fault Finding



Users must not attempt to repair the FXM5 if it is faulty, nor carry out fault diagnosis other than through the use of the diagnostic features described in this section.

Under no circumstances must the casing of the FXM5 be opened when the AC supply is connected.

If the FXM5 is faulty, it must be returned to an authorized Control Techniques distributor for repair.



Electric shock risk

If the FXM5 controller has been energized, the supply must be isolated for at least five minutes. This allows the internal capacitors to discharge fully before work may continue. Refer to *Safety information* on the inside front cover of this user guide.

Fault	Possible cause	Action
The AC supply isolator does not close	The field current is low, causing the field-failure relay to be de-energized.	Remove the cover and check all the fuses.
LED bar indicator indicates zero	Faulty field-winding connections. The SET MIN FIELD potentiometer is set at the fully anti-clockwise position.	Check the field winding connections. Check and, if necessary, adjust the SET MIN FIELD potentiometer.
LED bar indicator indicates maximum	No armature voltage signal applied to the FXM5 controller.	Check fuses FS1 and FS2.
The motor does not attain maximum speed	The SET MAX ARM V potentiometer is set too high or 6.07 is not set.	Adjust the potentiometer RV1 or parameter 6.07
The motor lacks torque and / or The field-failure relay trips when the motor is at high speed	The SET MAX ARM V potentiometer is set too low or 6.07 is too low or The SET MAX FIELD potentiometer or parameter 6.08 is too low.	Adjust the potentiometer RV1 or set parameter 6.07 Adjust RV2 or set parameter 6.08
The Drive trips on current over-load when the motor is normally loaded.	The maximum field current is set too low	Adjust the SET MAX FIELD potentiometer RV2 or parameter 6.08
The field-failure relay trips when the motor is under rapid acceleration	The minimum field current is set too low	Adjust the SET MIN FIELD potentiometer RV3 or parameter 6.10



0410-0011-05